

Spring End Grinding Machines for Compression Springs



G Series

G Series

▼ Grinding room with particulate deflector



▼ Grinding table and spring length measuring device (in-process)



Our Accomplishments for Your Benefit

- **Setup – Connection – Ready to Start, Spring End Grinding with WAFIOS!**
 - Standard machine includes all features needed to meet high demands with regard to quality and output
 - Latest drive concept, all down-feed movements are carried out by servoaxes
 - Automatic dressing of grinding wheels
 - Spring length measuring device guarantees a reliable production process
 - Laser sensors for automatic compensation of grinding wheel wear
- **Programming Is Easier Than Ever with WAFIOS and EasyWay!**
 - WPS 3.2 EasyWay
 - Geometrical programming
 - Clearly structured user interface
 - Complete machine and process data control
- **WAFIOS Technology:**
 - For Those Who Demand the Best!**
 - Solutions for process optimization (iQs)
 - iQtemperature:** Patented solution for temperature-controlled grinding
 - iQbestload:** Optimization of the loading process in relation to the grinding time
 - Patented particulate deflector avoids grinding dust deposits
 - Angular dressing of grinding wheels

Design Features

- Spring end grinding machines with 450 mm or 660 mm grinding wheel \varnothing for grinding both ends of compression springs
- Universal single-plate machine version with 580 mm or 740 mm loading plate \varnothing for down-feed and crush grinding operation
- Large-batch, double-plate machine version with 580 mm or 740 mm loading plate \varnothing for down-feed operation
- Grinding table with wear-resistant table plates
- Air showers for actively cooling the grinding process
- Noise-reduced protective hood
- Interface for loading and unloading equipment



▲ G 660 Double-plate machine version

Powerful, Safe and Precise – WAFIOS Spring End Grinding Machines

Excellent combination of solid and reliable technology

All standard machines guarantee optimum production conditions. They all feature an infinitely adjustable cutting speed, an automatic dressing process, laser-controlled compensation of the grinding wheel wear, spring length measurement as well as our reliable high-end control WPS 3.2 EasyWay with an automatic generation of programs.

Every machine can be adjusted to your needs as a huge range of options is available which includes hardware and software functions (some of them patented), e.g. unique **IQ software functions** for process optimization or **IQtemperature** for temperature-controlled grinding processes. Various interfaces allow communication with different peripheral devices, additional applications and automation solutions. Our open OPC-UA data interface is your access to the world of Industry 4.0.

Quality

For more than 125 years, the name of WAFIOS has been synonymous with highest quality, safety standards, and technical innovations in the German machine manufacturing industry.

Reliability

Strict quality controls, state-of-the-art production systems, and many years of experience guarantee that your investment is safe in our hands. Our global service network ensures high availability of WAFIOS machinery.

Cost efficiency

High production output and a long service life will save money and shorten the amortization time of your investment.

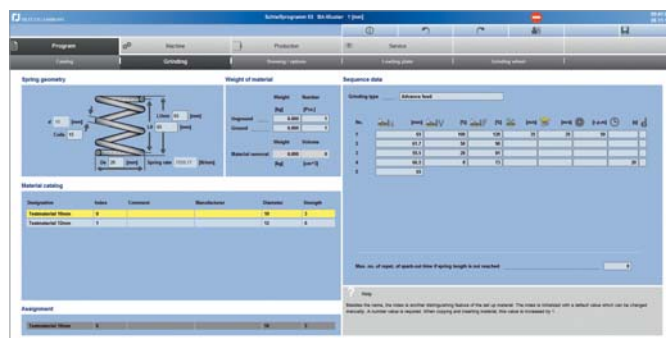

▲ WAFIOS programming system WPS 3.2 EasyWay

▼ Automatic dressing unit

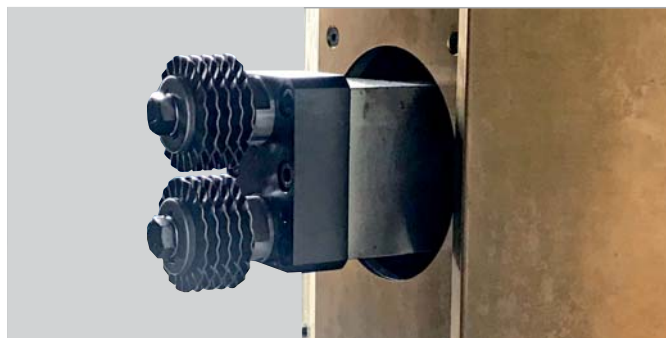

▲ Active cooling concept

Technical Data
Wire Ø depending on spring geometry: (mm)
Outer spring diameter: (mm)
Spring length: (mm)
Grinding wheels: (mm) (outer ø x height x bore hole ø)
Peripheral speed of grinding wheels: (m/s)***
Installed power, grinding spindles: (kW)
Loading plate speed: (rpm)***

G 450
1.0 - 9.0
max. 100
10 - max. 350
450 x 80 x 100
35 - 50
ca. 2 x 7.5
0.2 - 50

G 660
2.0 - 12.0
max. 140
12 - max. 350
660 x 100 x 150
35 - 50
ca. 2 x 11
0.2 - 50

Number of loading plates:
Loading plate diameter: (mm)
Spring reception hole, loading plate: (mm)**
Space required: (m) (without dust extraction) l x w x h
Weight: (kg) (without dust extraction)

1	1	2
580*	740*	580
50	60	50
2.1 x 2.2 x 2.9	2.2 x 2.2 x 2.9	2.4 x 2.2 x 2.9
ca. 3,600	ca. 3,625	ca. 4,500

1	2
740	740
60	60
3.0 x 3.0 x 3.0	2.4 x 3.6 x 3.0
ca. 6,300	ca. 7,200

* Loading plate size can be selected, conversion not possible!
 ** Different diameters are available
 *** Infinitely adjustable

▼ G 450 Single-plate Ø 580 mm

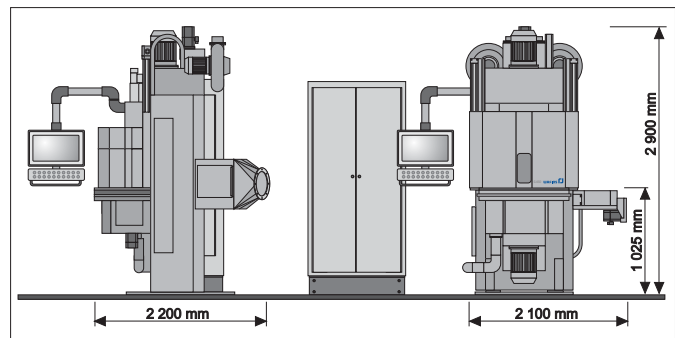

WAFIOS AG

Silberburgstraße 5
 72764 Reutlingen, Germany
 Phone +49 7121 146 - 0
 Fax +49 7121 146 - 250
 sales@wafios.de
 www.wafios.com

Precision Machinery for Wire and Tube