

ELECTRIC HEAVY-DUTY COMPACT FORKLIFT

ROX -
MINIMUM
SPACE
REQUIREMENT

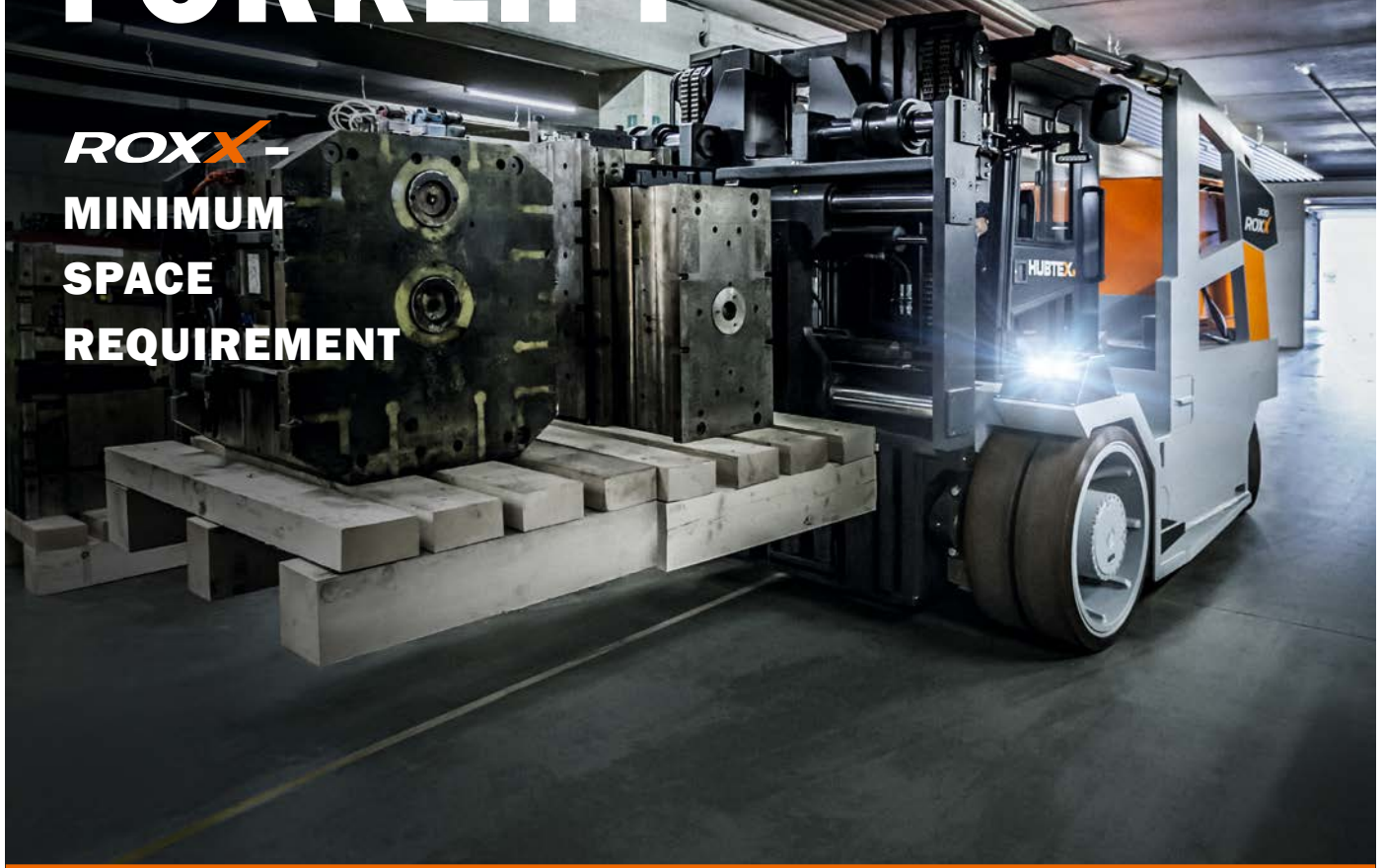

LOAD CAPACITIES UP TO 30.0 TONS
USER-SPECIFIC LIFT HEIGHTS

www.hubtex.com

HUBTEX.
WE CREATE THE UNIQUE

ROXX

POWERFUL YET COMPACT

The HUBTEX RoxX Electric Heavy-duty Compact Forklift is in its natural environment whenever heavy loads have to be transported, loaded or shipped in the tightest of spaces.

The RoxX can be used both indoors and outdoors. Compared to conventional forklifts, the RoxX boasts extremely compact dimensions in terms of length and width. In other words, the HUBTEX Compact Forklift can be used where conventional forklifts are not suitable due to their considerably larger dimensions.

All vehicles in the RoxX device series have a stable and robust free-view lift mast and offer maximum manoeuvrability and optimum all-round visibility from the driver's cabin.

Electric Heavy-duty Compact Forklift **ROXX** in detail

- Load capacities from 8 t to 30 t
- Environmentally friendly and quiet
- Electric drive
- Special free-view lift mast
- Indoor and outdoor applications
- Maximum manoeuvrability and space saving
- Optimum all-round visibility

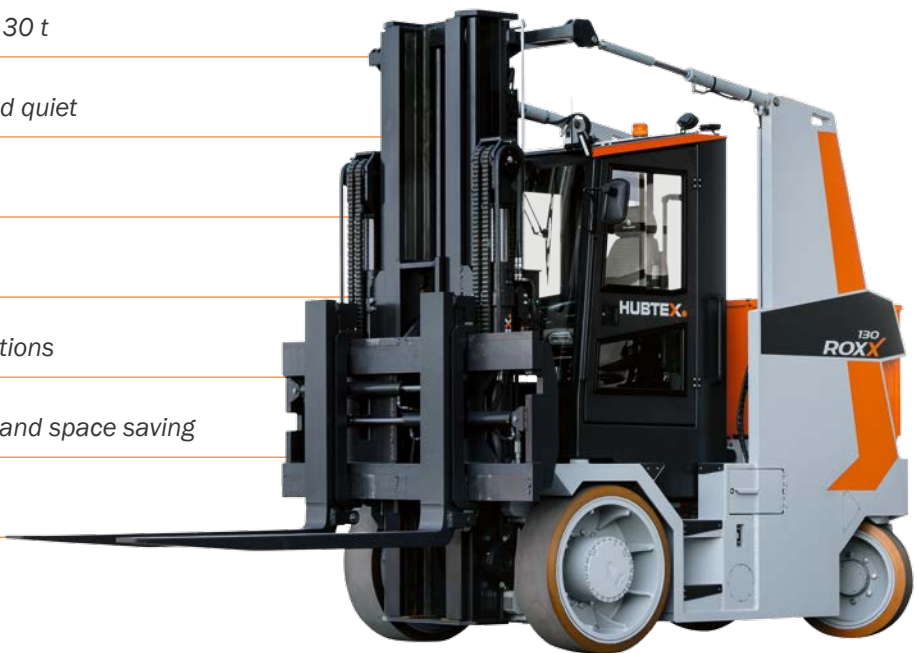

Thanks to the patented steering system, even the narrowest of spaces are accessible.



Features	RoxX
Load capacity (t)	8 – 30
Lift height (mm)	up to 10,000
Tyres	Elastic or PU
Lift height (mm)	User-specific
Cabin	Ergonomic seated driver's cabin
Operation	Multifunction joystick
Battery voltage (V)	80

Comfort and optimally equipped with the **ROXX**

➤ STEERING SYSTEM

Whether you are carrying coils, paper rolls, converters or die tools, the RoxX transports all loads safely and reliably. The RoxX offers significant advantages over classic forklifts, mainly due to its compactness. It is up to 25% narrower and around 20% shorter yet retains the same load capacity.

Two steering systems are also available for the RoxX. An **electro-hydraulic steering system** with a steering axle is installed as standard. Further space savings are possible with the optional available electric steering system.



Thanks to a new, patented **single-wheel steering system**, the turning radius is also significantly reduced. The reduction is around 50% compared to the standard steering system. In this case, the pivot point of the vehicle is ideally in the centre of the drive axle.



➤ LIFT MAST

The construction of the mast is crucial. On the one hand, the mast must be able to carry heavy loads and move safely, on the other, it must not restrict the driver's view.

We offer different versions of the mast for optimal flexibility. The masts range from a 2-stage Simplex lift mast (standard model) with maximum view of the load to a 2-stage lift mast with full free lift (Duplex) or a 3-stage lift mast with full free lift (Triplex) for low mast heights.

All models can be tilted from -5 degrees to $+5$ degrees.

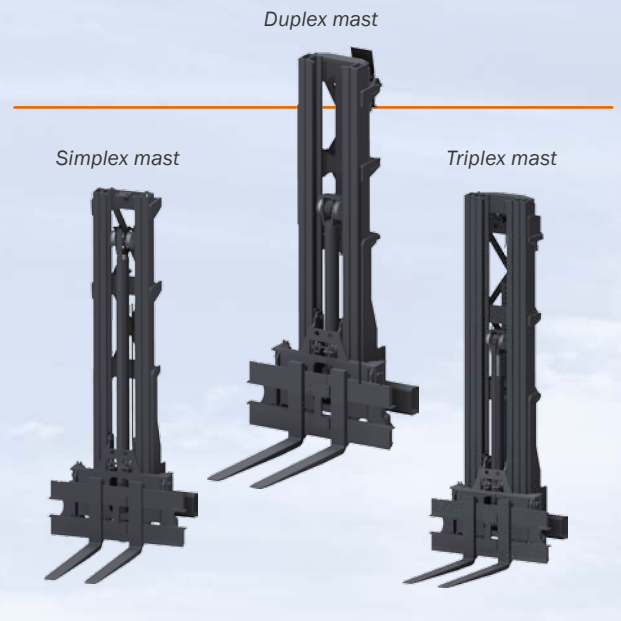



➤ CABIN

The optimally designed mast and the large window areas offer the driver an unobstructed all-round view from the spacious driver's cabin.

All hydraulic functions are controlled with the ergonomically arranged multifunction joystick. The vibration-dampened cabin and the sprung multi-adjustable seat, ensure fatigue-free and smooth operation. Non-slip steps allow easy and more importantly, safe entry.

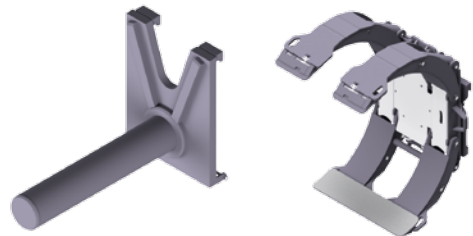

Depending on the requirements, the load is picked up using fork arms or the appropriate attachment.

➤ ELECTRIC DRIVE

The HUBTEX RoxX is electrically driven. This drive concept is 30% more efficient than a hydrostatic drive.





Foundry version of Heavy-duty Compact Forklift

Standard Heavy-duty Forklifts often have high maintenance and repair costs when used in foundries. This is due to the special requirements for foundries applications, for example when handling converters, sparks and splashes of liquid iron affects the difficult-to-protect components.

HUBTEX therefore decided to develop a completely new type of Heavy-duty Forklift. The design was precisely aligned to the production and operating conditions in a foundry. By using the foundry version of the HUBTEX Truck, ongoing service costs are greatly reduced, performance is enhanced and the total cost of ownership is significantly reduced.

➤ ADVANTAGES COMPARED TO THE STANDARD VERSION:

- Protection of temperature-sensitive parts, such as hydraulic lines
- Installation of the entire drive and control technology inside the vehicle
- Protected inside hydraulic lines in the mast
- Significantly improved visibility through the use of a telescopic arm
- Washers with quick change system in the cabin
- Wheel arches protect the tyres from damage
- Lower axle loads to reduce the point load on the building floors



HUBTEX VEHICLES

ELECTRIC-MULTIDIRECTIONAL-SIDELOADERS › DIESEL-/GAS-FOUR-WAY-SIDELOADERS › MULTIDIRECTIONAL COUNTERBALANCE FORKLIFT › ORDER PICKING SYSTEMS › GLASSTRANSPORT SYSTEMS › HEAVY DUTY TRANSPORT VEHICLES › REACH TRUCKS › SPECIAL TRUCKS › SECOND-HAND-AND RENTAL EQUIPMENT

HUBTEX.

WE CREATE THE UNIQUE

HUBTEX MASCHINENBAU GMBH & CO. KG · Industriepark West · Werner-von-Siemens-Str. 8 · 36041 Fulda, Germany
Tel.: +49 661 8382-0 · Fax: +49 661 8382-120 · info@hubtex.com · www.hubtex.com